

Kanlux



Kanlux XLED HP D90

Kanlux XLED HP D90E27 is the LED equivalent of specialised halogen bulbs with an E27 cap. This professional light source has a luminous efficacy of over 150lm/w making it more efficient than its halogen antecedent and helping to save on electricity expenses. In addition, it has a service life of 25,000 hours.

- For industrial applications (e.g. in manufacturing floors, warehouses, etc.)
- 3 years Warranty under the terms of the warranty statement, available on our website
- The product fulfills IP65 requirements except lamp cap, outdoor applications require the lamp to be used in luminaires with suitable IP rating. Lamp cap needs to be installed in correct IP rated socket.

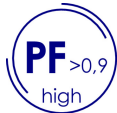

 220-240 AC	 50	 FILAMENT	 360° Φuse	 ellipse ≤ 6x Mackdam	 80	 ≥7500
 25000	 Hg		 -20÷45	 IP 65		



XLED HP D90E27 26W-NW



XLED HP D90E27 26W-NW	37346	26	227	4000	4000	320	E27	D
XLED HP D90E40 36W-NW	37348	36	327	6000	4000	320	E40	C



XLED HP D90E27 26W-NW



XLED HP D90E40 36W-NW

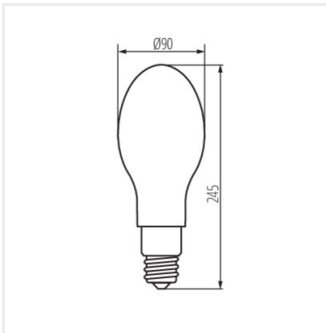

XLED HP D90E27 26W-NW

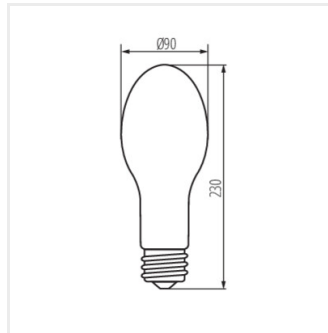

XLED HP D90E40 36W-NW

Date of issue: 18.11.2024, 09:26

We reserve the right to make technical changes. The data contained in this material are not legally binding.

Photometry: the results obtained from testing were from a specific sample.