

## STRETON LED

світильник для парковки LED



$[V]$ 220-240 AC	$[Hz]$ 50	$360^\circ$ $\Phi_{use}$	$\geq 20000$	$50000$	ellipse $\leq 6x$ MacAdam	Ra 70
SMD			IP 65		$-20 \div 45$	IK 08
	$0,4$ [m]	$1$ [mm <sup>2</sup> ]	$1m$		CE	EAC
UK CA						



### STRETON LED 60W NW



	PON	[lm]	Tc [K]	[°]		
STRETON LED 60W NW	<b>36230</b>	60	8400	4000	X140/Y90	сірий D
STRETON LED 100W NW	<b>36231</b>	100	14000	4000	X140/Y90	сірий D
STRETON LED 150W NW	<b>36232</b>	150	19500	4000	X140/Y90	сірий E
STRETON LED 200W NW	<b>36233</b>	200	26000	4000	X140/Y90	сірий E

- 5 років Гарантії на умовах гарантійної заяви, доступної на веб-сайті
- Матеріал корпусу: сплав алюмінію
- Матеріал захисного скла: PC

## STRETON LED

світильник для парковки LED



STRETON LED 60W NW



STRETON LED 100W NW



STRETON LED 150W NW



STRETON LED 200W NW

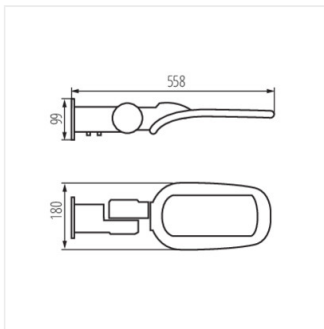

STRETON LED 60W NW

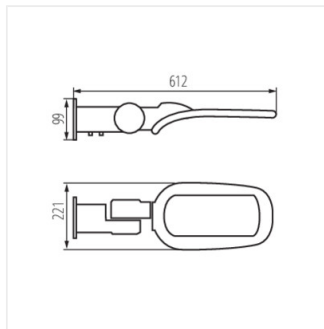

STRETON LED 100W NW

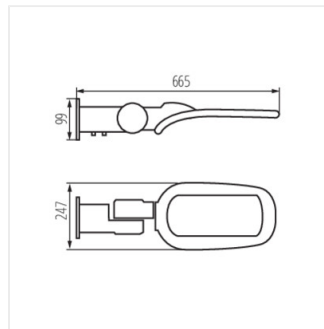

STRETON LED 150W NW

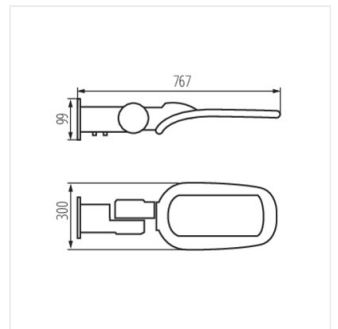

STRETON LED 200W NW

## STRETON LED

---

світильник для парковки LED

### OPTION 1

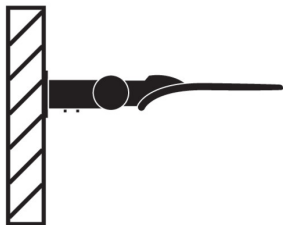

### OPTION 2

