

24904 DOMO 01-1140-241 gr

Staircase LED switch

5905339249043

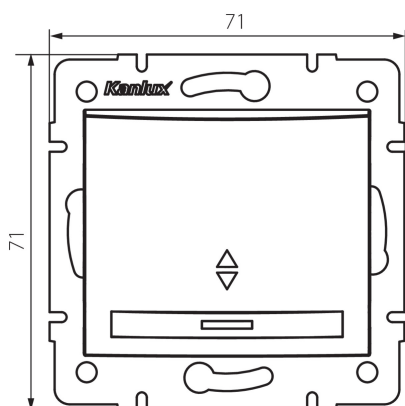

GENERAL DATA:

Colour: graphite
Place of assembly: Recessed mount in the wall
Highlighting: yes
Width [mm]: 71
Height [mm]: 71
Diameter of an installation box: 60
Installation depth: 25

TECHNICAL DATA:

Rated voltage [V]: 250 AC
Material: PC
Material of contacts: CuSn94
Terminal type: Quick-fit coupling
Plastic: PC
Number of levers: 1
Rated current [AX]: 10
IP class: 20

LOGISTIC DATA:

Packaging method: 10
Number of units in the secondary packaging: 10
Number of units in the packaging: 120
Net unit weight [g]: 80
Grammage [g]: 93.75
Length of a unit pack [cm]: 10
Width of a unit pack [cm]: 4.5
Height of a unit pack [cm]: 14
Weight of a cardboard box [kg]: 11.25
Width of a cardboard box [cm]: 25.5
Height of a cardboard box [cm]: 32
Length of a cardboard box [cm]: 44
Volume of a cardboard box [m³]: 0.035904

24904 DOMO 01-1140-241 gr

Staircase LED switch