

## 25368 DOMO 01-1050-250 sz

Staircase switch

5905339253682

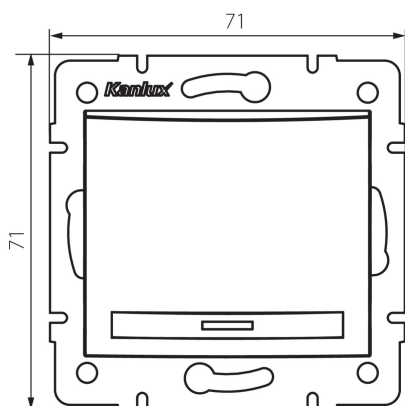

### GENERAL DATA:

**Colour:** champagne  
**Place of assembly:** Recessed mount in the wall  
**Highlighting:** Not applicable  
**Width [mm]:** 71  
**Height [mm]:** 71  
**Diameter of an installation box:** 60  
**Installation depth:** 25

### TECHNICAL DATA:

**Rated voltage [V]:** 250 AC  
**Material:** PC  
**Material of contacts:** CuSn94  
**Terminal type:** Quick-fit coupling  
**Plastic:** PC  
**Number of levers:** 1  
**Rated current [AX]:** 10  
**IP class:** 20

### LOGISTIC DATA:

**Packaging method:** 10  
**Number of units in the secondary packaging:** 10  
**Number of units in the packaging:** 120  
**Net unit weight [g]:** 78  
**Grammage [g]:** 91.75  
**Length of a unit pack [cm]:** 10  
**Width of a unit pack [cm]:** 5  
**Height of a unit pack [cm]:** 14  
**Weight of a cardboard box [kg]:** 11.01  
**Width of a cardboard box [cm]:** 25.5  
**Height of a cardboard box [cm]:** 32  
**Length of a cardboard box [cm]:** 44  
**Volume of a cardboard box [m³]:** 0.035904

**25368** DOMO 01-1050-250 sz

---

Staircase switch